

INSTALLATION OPERATION AND SERVICE MANUAL MICROFLAME SERIES 2



GAS FIRED COMMERCIAL COPPER TUBE BOILERS



FOR HYDRONIC HEATING

Models; MFH800, 1000, 1200, 1400, 1600, 1800, 2000



HOT WATER SUPPLY

Models; MFW800, 1000, 1200, 1400, 1600, 1800, 2000



WARNING: If the information in these instructions is not followed exactly, a fire or explosion may result causing property damage, personal injury or death

- Do not store or use gasoline or other flammable vapours and liquids in the vicinity of this or any other appliance.
- **WHAT TO DO IF YOU SMELL GAS**
 - Do not try to light any appliance,
 - Do not touch any electrical switch; do not use any phone in your building,
 - Immediately call your gas supplier from a neighbour's phone. Follow the gas supplier's instructions,
 - If you cannot reach your gas supplier, call the fire department.
- Qualified installer, service agency or the gas supplier must perform installation and service.

To the installer: After installation, these instructions must be given to the end user or left on or near the heater.
To the End User: This booklet contains important information about this heater. Retain for future reference.

CAMUS HYDRONICS LTD.

6226 Netherhart Road, Mississauga, Ontario, L5T 1B7

Table of Contents

- INTRODUCTION 1
- 1. GENERAL INSTRUCTIONS 1
- 2. BOILER LOCATION 2
- 3. PROVIDE AIR FOR COMBUSTION AND VENTILATION 3
- 4. ELECTRICAL WIRING 3
- 5. STAGING OPERATION 4
- 6. GAS SUPPLY AND PIPING 5
- 7. VENTING 6
 - 7.1 OUTDOOR VENTING 8
 - 7.2 SIDEWALL VENTING 9
 - 7.3 OUTDOOR AIR KIT 9
 - 7.4 FILTER KIT 10
 - 7.5 STANDARD VENTING 10
 - 7.6 VENTING FOR CONDENSING APPLICATION 10
- 8. RELIEF VALVE 10
- 9. FREEZE PROTECTION 10
- 10. WARNING REGARDING CHILLED WATER SYSTEMS 11
- 11. PIPING OF SYSTEM TO BOILER (FIG.4) 11
- 12. PLACING BOILER IN OPERATION 13
- 13. IGNITION SYSTEM SAFETY SHUT-OFF DEVICE 13
- 14. LOW WATER TEMPERATURE SYSTEMS 13
- 15. INSTANTANEOUS WATER HEATER 14
- 16. PILOT AND MAIN BURNER FLAMES 15
 - 16.1. MAIN BURNER 15
 - 16.2. PILOT BURNER 17
- 17. OPERATION AND SERVICE 18
- 18. LIGHTING INSTRUCTIONS 19
- 19. TROUBLE SHOOTING GUIDE 20
- 20. TYPICAL GAS TRAIN 21
- 21. ELECTRICAL DIAGRAMS 21
- 22. EXPLODED VIEW 24
- 23. MICO FLAME REPLACEMENT PARTS LIST 25
- WARRANTY 26

INTRODUCTION

Camus Hydronics proudly introduces its MicoFlame series 2 of commercial water heaters / hydronic boilers. These gas-burning appliances are thoughtfully designed for easy operation and maintenance. We are confident that you will come to appreciate the benefits of our product.

1. GENERAL INSTRUCTIONS

The installation of this heater must conform to the requirements of the authority having jurisdiction or, in the absence of such requirements, to the National Fuel Gas Code, ANSI Z223.1 or CAN/CGA B149 Installation Codes. All electrical wiring must be done in accordance with the requirements of the authority having jurisdiction or, in the absence of such requirements, with the National Electrical Code, ANSI/NFPA 70 or the Canadian Electrical Code Part I , CSA C22.1 Electrical Code .

Vent installations must be in accordance with Part 7, Venting of Equipment, of the National Fuel Gas Code, ANSI Z223.1, or Section 7, Venting Systems and Air Supply for Appliances, of the CAN. CGA B149, Installation Codes and applicable provisions of the local building codes.

When required by the authority having jurisdiction, the installation must conform to the Standard for Controls and Safety Devices for Automatically Fired Boilers, ANSI/ASME CSD-1.

The qualified installer shall instruct the end user in the safe and correct operation of this appliance and shall ensure that the heater is in safe working order prior to leaving the job site.

WARRANTY:

Factory warranty shall apply only when the boiler is installed in accordance with local plumbing and building codes, ordinances and regulations, the printed instructions provided with it and good industry practices.

Excessive water hardness causing a lime build-up in the copper coils or tubes is not a fault of the boiler and is not covered by warranty. Consult the factory for recommendations for use in hard water areas.

Using or storing corrosive chemicals in the vicinity of this boiler can rapidly attack the copper tubes and coils and voids warranty.

The primary heat exchanger of this boiler is intended to operate under non-condensing conditions. Inlet temperatures must be maintained at 110 °F or higher. Warranty is void if the primary heat exchanger is allowed to operate in condensing mode.

Damage caused by freezing or dry firing voids warranty.

This boiler is not to be used for temporary heating of buildings under construction.

2. BOILER LOCATION

Install this boiler in a clean, dry location with adequate air supply and close to a good vent connection.

Do not locate this boiler in an area where it will be subject to freezing.

The boiler must not be installed on carpeting and should be located close to a floor drain in an area where leakage from the boiler or connections will not result in damage to the adjacent area or to lower floors in the structure.

If necessary a suitable drain pan should be installed under the boiler.

If the boiler is installed above the level of the building's radiation system, a low water cutoff device must be installed in the boiler outlet at the time of installation. Some local codes require the installation of a low water cutoff on all systems.

Locate the boiler so as to provide adequate clearance for inspection and service all around the unit. It is recommended that 24" be provided for the top and sides and 48" for the front.

This boiler is suitable for alcove installation with minimum clearances to combustibles as follows:

TOP:	12"
SIDES:	12"
REAR:	12"
VENT:	6"

For boiler's dimensions see Figure 1 and table 1

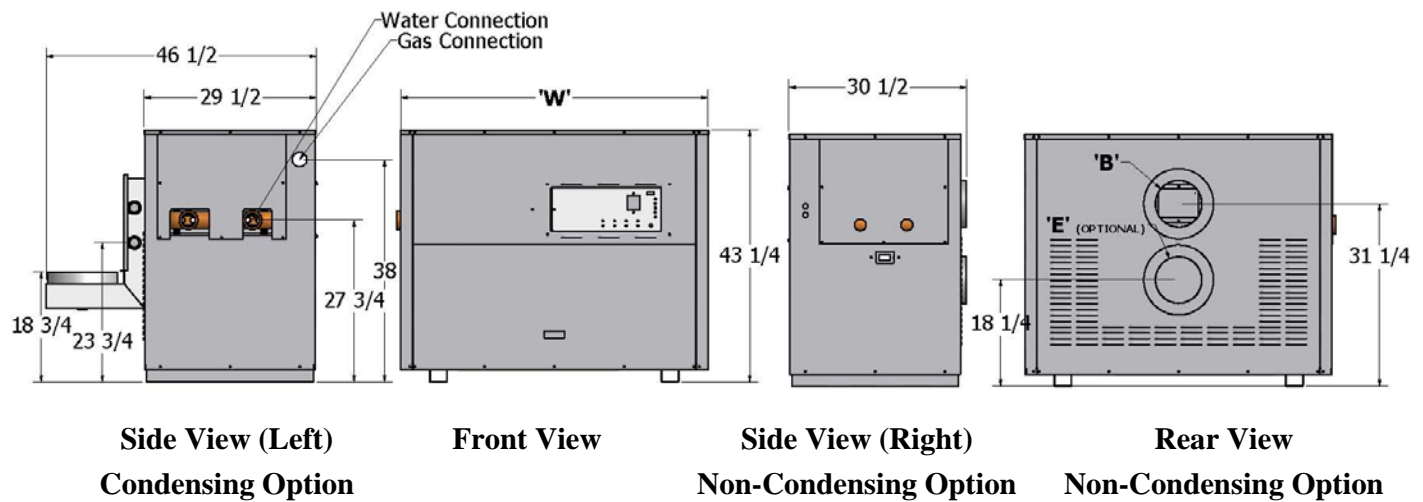

Figure 1

Model	W'	Water Connection	Gas Connection	B' Dia. Venting			E' Dia.
				Outdoor	Condensing or Sidewall	Standard	Air Inlet
MF800	45 3/4	2 1/2	1	8	8	10	8
MF1000	52 3/4	2 1/2	1 1/4	8	8	10	8
MF1200	62	2 1/2	1 1/4	10	10	12	10
MF1400	71 1/4	2 1/2	1 1/4	10	10	12	10
MF1600	80 3/4	2 1/2	1 1/2	12	12	14	12
MF1800	89 3/4	2 1/2	1 1/2	12	12	14	12
MF2000	99	2 1/2	1 1/2	12	12	14	12

Table 1

3. PROVIDE AIR FOR COMBUSTION AND VENTILATION

Provisions for combustion and ventilation air must be in accordance with:

- Section 5.3. Air for combustion and Ventilation, of the National Fuel Gas Code, ANSI Z223.1, or;
- Sections 7.2, 7.3 or 7.4 of CAN/CGA B149 Installation Codes, and;
- Applicable provisions of the local building codes.

The operation of exhaust fans, compressors, air handling units etc. can rob air from the room, creating a negative pressure condition leading to reversal of the natural draft action of the venting system. Under these circumstances an engineered air supply is necessary.

If the heater is to be installed near a corrosive or potentially corrosive air supply, the heater must be isolated from it and outside air should be supplied as per code.

Potentially corrosive atmospheres will result from exposure to permanent wave solution, chlorinated waxes and cleaners, chlorine, water softening chemicals, carbon tetrachloride, halogen based refrigerants, Freon cleaning solvents, hydrochloric acid, cements and glues, masonry washing materials, antistatic fabric softeners, dry cleaning solvents, degreasing liquids, printing inks, paint removers, etc.

4. ELECTRICAL WIRING

All electrical wiring to the boiler must be electrically bonded to ground in accordance with the requirements of the authority having jurisdiction or, in the absence of such requirements, with the National Electrical Code, ANSI/NFPA 70 or the Canadian Electrical Code Part I, CSA C22.1, Electrical Code.

Provide disconnecting means of sufficient rating within sight of the boiler. These heaters require an 115V 60hz supply. Depending on the pump used, a 15-amp breaker is usually sufficient.

Electrical connections must be made so that the circulator will operate before the gas valve can open. At no time may the control system allow the burner to fire without water flowing in the system.

Use minimum 18-gauge conductor for 24-volt field wiring to boiler. Splicing of wires is not recommended.

Use sealed tight conduit suitable for outdoor use for outdoor installations.

Use terminal strip provided inside control panel for low water cut-off and remote controller

Refer to wiring diagram provided with boiler.

5. STAGING OPERATION

Staging of the MicoFlame series 2 is dependent on the number of burners supplied. Models 800 and 1000 are supplied with a single burner and are available as on/off and two stages. Models 1200 through 2000 are supplied with two burners and are available as on/off, 2-stage, 3-stage and 4-stage.

Each burner is supplied with a dedicated airflow proving signal and separate proved pilot ignition system. All fans must be running in order for the appliance to proceed to trial for ignition.

MicoFlame series 2 is supplied with more than one burner may use burners that are not of identical size in order to accommodate fans within the space allocated. In case where burners are not identical, the right side burner will be the one with the higher input.

Each MicoFlame series 2 is supplied with the appropriate wiring diagram showing the actual staging sequence provided as well as any special controls or options requested.

When converting multiple MicoFlame series 2 appliances to an external sequencing control it is absolutely necessary to program the sequencer properly by entering the number of stages provided on the appliance. In this way the sequencer will lead/lag or rotate the boilers properly.

A full diagnostics panel is provided on the MicoFlame series 2. On a call for heat, status lights will light up if the particular safety is working properly. Once all safeties have been proved, the boiler will proceed to trial for ignition and will then sequentially bring on the burner stages (and the corresponding lights). If the safety proving sequence does not proceed to completion, the first safety light to remain off will indicate the cause of the problem. All other lights below the problem indicator light will also remain off.

Burner staging is arranged to allow a minimum firing rate of no less than 50% in order to minimize possibility of condensation in the venting. Staging of burners for models 1200 through 2000 is as follows:

Two Stage	Left Burner	Right Burner
Stage 1	Off	Full-Fire
Stage 2	Full Fire	Full-Fire

Three Stage *	Left Burner	Right Burner
Stage 1	Off	Lo-Fire
Stage 2	Off	Hi-Fire
Stage 3	Full-Fire	Hi-Fire

* Recommended for Models 1400 and 1600

Four Stage	Left Burner	Right Burner
Stage 1	Off	Lo-Fire
Stage 2	Off	Hi Fire
Stage 3	Lo-Fire	Hi-Fire
Stage 4	Hi-Fire	Hi-Fire

6. GAS SUPPLY AND PIPING

This boiler is intended to operate at inlet gas pressures not exceeding ½ PSI (14" W.C.). If higher pressures are present, consult the gas company for correction.

When pressure testing the gas supply piping at pressures above ½ PSI, the boiler and its individual gas shut-off valve must be disconnected from the supply piping.

Provide a trap (drip leg) as close to the heater as possible.

Install a good joint union and manual shut-off valve in the gas line near the heater to allow easy removal of the gas control assembly.

Provide gas pressures at inlet to boiler manifold as follows:

	PROPANE	NATURAL GAS
Minimum (inches W.C.)	11	4
Maximum (inches W.C.)	11	7

The gas supply line must be of adequate size to prevent undue pressure drop and must never be smaller than the size of the connection on the heater. Sizing based on Table 2 is recommended.

Before operating the boiler, the complete gas train and all connections must be tested using soap solution.

DISTANCE FROM NATURAL GAS METER OR PROPANE SECOND STAGE REGULATOR						
Input Btu/Hr	0-100 FT		100-200 FT.		200-300 FT.	
	NAT.	L.P.	NAT.	L.P.	NAT.	L.P.
800,000	2"	1 ½"	2 ½"	2"	2 ½"	2"
1,000,000	2"	1 ½"	2 ½"	2"	2 ½"	2"
1,200,000	2 ½"	2"	2 ½"	2"	3"	2 ½"
1,400,000	2 ½"	2"	2 ½"	2"	3"	2 ½"
1,600,000	2 ½"	2"	3"	2 ½"	3"	2 ½"
1,800,000	2 ½"	2"	3"	2 ½"	3"	2 ½"
2,000,000	2 ½"	2"	3"	2 ½"	3"	2 ½"

Table 2

7. VENTING

Boilers for outdoor installation are intended to vent using a listed vent cap.

For indoor installations venting must be in accordance with Part 7, Venting of Equipment, of the National Fuel Gas Code, ANSI Z223.1, or Section 7, Venting of Equipment and Air Supply for Appliances, of the CAN/CGA B149, Installation Codes, and applicable provisions of the local building codes.

Vent connectors serving appliances vented by natural draft shall not be connected into any portion of mechanical draft systems operating under positive pressure.

Horizontal runs of vent pipe shall be securely supported (approximately every 4 feet) to prevent sagging and maintain a minimum upward slope of ¼" per foot from the boiler to the vent terminal.

When an existing boiler is removed from a common venting system, the common venting system is likely to be too large for proper venting of the appliances remaining connected to it .At the time of removal of an existing boiler, the following steps must be followed with each appliance remaining connected to the common venting system placed in operation, while the other appliances remaining connected to the common venting system are not in operation.

- a) Seal any unused openings in the common venting system.
- b) Visually inspect the venting system for proper size and horizontal pitch and determine that there is no blockage, restriction, leakage, corrosion or other deficiency, which could cause an unsafe condition.
- c) Insofar as is practical, close all building doors and windows and all doors between the space in which the appliances remaining connected to the common venting system are located and other spaces of the building. Turn on the clothes dryers and any appliances not connected to the common venting system. Turn on any exhaust fans, such as range

hoods and bathroom exhausts, so they will operate at maximum speed, do not operate a summer exhaust fan. Close fireplace dampers.

- d) Place in operation the appliance being inspected. Follow the lighting instructions. Adjust thermostat so that appliance operates continuously.
- e) Test for spillage at the draft hood relief opening after 5 minutes of main burner operation. Use the flame of a match or candle or smoke from a cigarette.
- f) After it has been determined that each appliance remaining connected to the common venting system properly vents when tested as outlined above, return doors, windows, exhaust fans, fireplace dampers and any other gas-burning appliance to their previous condition of use.
- g) Any improper operation of the common venting system must be corrected so that the installation conforms to the National Fuel Gas Code, ANSI Z223.1 or CAN/CGA B149, Installation Codes. When resizing any portion of the common venting system, the common venting system should be resized to approach the minimum size as determined using the appropriate tables in Part 11 of the National Fuel Gas Code, ANSI Z223, 1 or CAN/CGA B149, Installation Codes.

Heat exchanger surfaces and vent piping should be checked every six months for deterioration and carbon deposits. Remove all soot or other obstructions from the chimney and flue, which might impede draft action. Replace any damaged or deteriorated parts of the venting system.

A qualified service technician should follow this procedure when inspecting and cleaning the heat exchanger and vent pipe.

1. Turn off electrical power and close main manual gas shut-off and allow boiler to cool down
2. Remove the vent pipe running to chimney. Remove top outer panel and flue collector access panel. Check heat exchanger, vent and chimney for obstruction and clean as necessary.
3. Remove burner from boiler and vacuum the burner, and the heat exchanger. If heat exchanger is excessively dirty it may be necessary to remove it from the boiler and wash it down with proper detergent cleaner. Be aware that the combustion chamber base is insulated with ¼" thick ceramic paper. If this material is damaged or displaced it must be replaced before starting up the boiler.
4. Reinstall parts removed in steps 2 and 3. Be sure that vent pipe has proper pitch and is properly sealed. Repair or replace any gaskets, which may have been damaged in steps 2 and 3.
5. **CAUTION:** When replacing the burner be careful to fully engage the back of the burner box into the retaining slot in the combustion chamber base. Failure to properly locate the burner will result in erratic flame operation with the possibility of delayed ignition on light off.
6. Restore electrical power and gas supply to boiler.
7. Place boiler in operation using lighting instructions provided.

- While the boiler is operating, check for flue gas leaks and proper vent operation. Seal any flue gas leaks using appropriate gasket or sealing material. Carefully examine the flue collector access panel and heat exchanger ends.

The MicoFlame series 2 is category 1, 85% efficient when supplied as a non-condensing appliance. When supplied with the optional condensing cartridge, the MicoFlame series 2 is 95% efficient and is considered to be a category II or IV appliance. Three venting options are available for this boiler in both condensing and non-condensing configurations. See Figure 2 for details. (Please refer to Table 1 for vent dimensions)

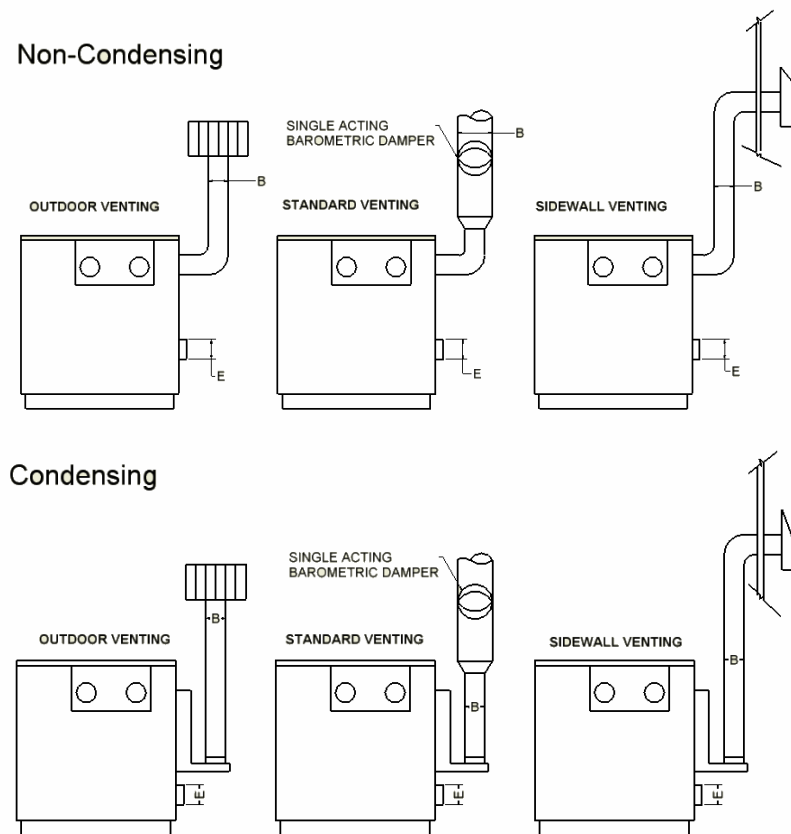

Figure 2

7.1 OUTDOOR VENTING

When fitted with the factory supplied rain shield and UL approved vent cap, the MicoFlame series 2 is self-venting. The following applies to outdoor installations:

- Use only factory supplied rain shields.
- Periodically check to ensure that air intake and vent cap are not obstructed.
- Locate boiler at least 3 feet away from any overhang.

4. Locate boiler at least ten feet from building air intake.
5. Avoid installation in areas where runoff from adjacent building can spill onto boiler.

7.2 SIDEWALL VENTING

When fitted with the factory supplied vent terminal, the MicoFlame series 2 can vent up to 60 equivalent feet. Elbows can range from 8 to 15 feet in equivalent length depending on centreline radius. See Table 1 for vent sizes.

Boilers may be installed with either a horizontal sidewall vent or vertical roof top terminal. Terminals differ with each application. Horizontal lengths over 5 feet must be installed using corrosion resistant stainless steel. Use single wall vent and seal all joints or use pressure rated double wall vent.

Refer to local codes for proper installation and location of vent terminals.

When using sidewall vent, all vent connector seams and joints must be sealed with pressure sensitive aluminium tape or silicone sealant as specified by the vent manufacturer. Aluminium tape must meet the provisions of SMACNA AFTS-100-73 Standard.

When venting through unheated spaces with single wall vent, insulation should be wrapped around the vent pipe to prevent flue gas condensation inside the vent.

Periodically check to ensure that the vent terminal is unobstructed.

7.3 OUTDOOR AIR KIT

When fitted with the factory supplied air inlet ring and air intake terminal, the MicoFlame series 2 can draw outdoor air over an equivalent length of 60 feet. See Table 1 for vent sizes.

Boilers may be installed with either a horizontal sidewall vent or vertical roof top terminal. Terminals differ with each application.

The following applies to outdoor air installations:

1. Use only factory supplied air intake terminal.
2. Periodically check to ensure that air intake is not obstructed.
3. Refer to local codes for proper installation and location of vent terminals. Vertical vent terminal must be at least 3 feet above the highest point where it is located above the roof of a building and at least two feet higher than any part of the building within a horizontal distance of ten feet
4. Locate the air intake five feet away from the vent discharge. For sidewall venting locate the air intake below the vent outlet if possible.

7.4 FILTER KIT

A louvered rear panel is the standard air inlet configuration for the MicoFlame series 2. A filter kit is available. The filter is washable and accounts for an additional pressure loss of less than 0.05" W.C. Highly recommended for dusty environments.

The filter kit can also be provided when using the outdoor air kit.

7.5 STANDARD VENTING

The MicoFlame series 2 is a category 1 appliance and is approved for venting into a common standard chimney. If chimney height is much greater than 30 feet or if drafts are excessive, it may be preferable to provide a single acting barometric damper directly above the vent collar. This damper will ensure smooth light off and minimize standby loss through the boiler. Be sure to position the damper at least 6 " away from the wall of the vent connector.

7.6 VENTING FOR CONDENSING APPLICATION

When supplied with the optional condensing cartridge, the MicoFlame series 2 is 95% efficient (category II or IV appliance) which requires the use of special venting system. Refer to installation instruction No. 93-0152-1. Only venting components listed by a nationally recognized testing agency may be used.

8. RELIEF VALVE

A pressure relief valve is supplied as standard equipment. The relief valve protects against damage that could be caused by malfunctioning controls or excessive water pressure. If a relief valve is not used, warranty is void.

The relief valve is to be located as near as practical to the outlet of the boiler. To maintain capacity do not reduce the inlet connection of the relief valve. Connect the outlet of the relief valve to a suitable drain. The drainpipe must point down from the valve and must not be smaller than the outlet of the valve. The end of the drain line should not be concealed or threaded and should be protected against freezing. No valve of any kind should be installed between the relief valve and the unit or in the drain line. Extensive runs, traps or bends could reduce the capacity of the valve. This valve should be checked for proper operation at least once a year by a qualified service technician.

9. FREEZE PROTECTION

Boiler installations are not recommended in areas where the danger of freezing exists unless precautions are taken. Maintaining a mixture of 50% water and 50% propylene glycol is the preferred method of freeze protection in hydronic systems. This mixture will protect the boiler to approximately -35 °F (-37 °C). To maintain the same temperature rise across the boiler increase the G.P.M. flow by 15% and the head loss by 20%.

A snow screen should be installed to prevent snow and ice accumulation around the boiler. Regular inspections should be made to ensure that air intake and vent are free of snow and ice.

10. WARNING REGARDING CHILLED WATER SYSTEMS

When a boiler is connected to an air conditioning system where the same water is used for heating and cooling, the chiller must be piped in parallel with the boiler. Appropriate flow control valves; manual or motorized must be provided to prevent the chilled water from entering the boiler. (See figure 3)

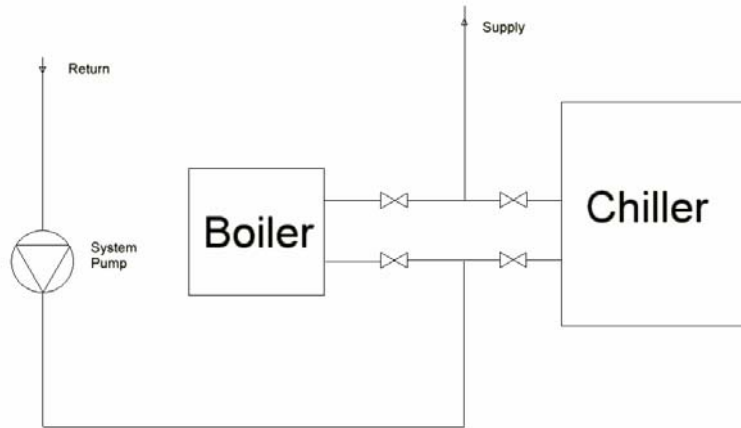

Figure 3

When a boiler is connected to heating coils located in air handling units (where they may be exposed to refrigerated air circulation), the boiler piping system shall be equipped with a flow control valve or other automatic means to prevent gravity circulation of chilled water through the boiler. Chilled water in the boiler will create condensate on the boiler tubes, which will collect in the combustion chamber causing corrosion.

11. PIPING OF SYSTEM TO BOILER (FIG.4)

Check all applicable local heating, plumbing and building safety codes before proceeding.

Be sure to provide unions and gate valves at inlet and outlet to boiler so that it can be easily isolated for service.

This boiler is of a low mass design, which provides for instant heat transfer. Special attention to water flow rates will ensure that temperature rise does not exceed 35 °F (19.4 °C). The following table 3 is provided as a guide.

For application in areas known to have hard water conditions, contact factory for recommendations.

Head Loss and Flow Vs Temperature Rise

Model	20 °F		30 °F		35 °F	
	USGPM	ΔP ft.	USGPM	ΔP ft.	USGPM	ΔP ft.
800	66.6	2.8	44.4	1.1	38.0	0.8
1000	83.3	4.9	55.5	2.0	47.6	1.5
1200	100.0	6.9	66.7	3.1	57.1	2.4
1400	*	*	77.8	4.3	66.7	3.4
1600	*	*	88.9	5.4	76.2	4.0
1800	*	*	100.0	6.9	85.7	5.1
2000	*	*	*	*	95.2	6.2

* Contact factory for recommendations

Table 3

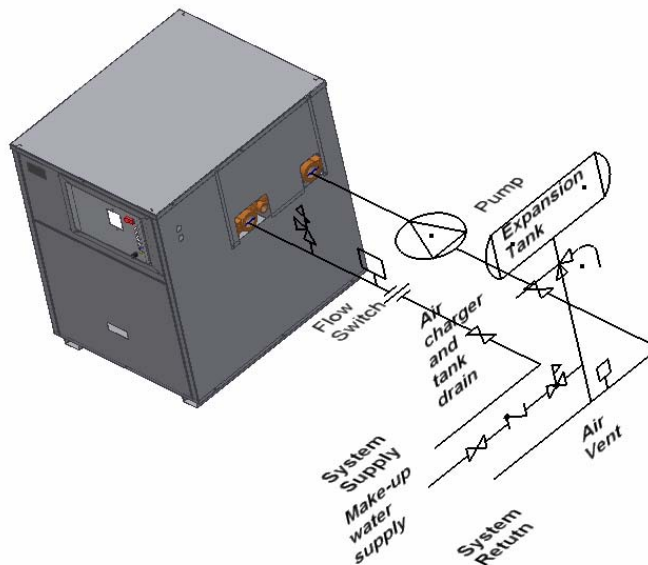

Figure 4

If the boiler is installed above radiation level, it must be provided with a low water cutoff device at the time of boiler installation. (Available from factory)

A pressure relief valve is supplied with each MicoFlame series 2 boiler. The relief valve must be piped to the floor in a manner acceptable to the enforcing authority.

To eliminate trapped air, install venting devices at high points in the system as well as in the piping on the suction of the pump and in the piping on the discharge of the boiler.

Suitable pipe hangers must support the weight of all water and gas piping or floor stands.

Do not allow the boiler to run with inlet water temperature below 110 °F.

The boiler must be installed so that the gas ignition system components are protected from water (dripping, spraying, rain, etc.) During appliance operation and service (circulator replacement, control replacement, etc.)

12. PLACING BOILER IN OPERATION

The MicoFlame series 2 boiler should be installed and started up by qualified personnel.

With the boiler off, open makeup water valve and allow system to fill slowly. Adjust the pressure regulator to provide at least 15 PSIG at the highest point in the system.

With all air vents open, run system circulating pump for a minimum of 30 minutes with the boiler off.

Open all strainers in the circulating system and check for debris.

Check liquid level in expansion tank. With system full of water at 15 PSIG, the level of water in the expansion tank should not exceed $\frac{1}{4}$ of the total volume with the balance filled with air.

Start up boiler following instructions provided. Operate entire system including pumps and radiation for at least 1 hour.

Check water level in expansion tank. If level exceeds $\frac{1}{2}$ of tank volume, air is still trapped in system. Shut down boiler and continue to run pumps.

Within 3 days of start up, recheck all air vents and expansion tank as described above.

13. IGNITION SYSTEM SAFETY SHUT-OFF DEVICE

After initial fill while the main burner is firing, shut off gas to the pilot and clock the time taken for the main gas valve to shut down. If the safety control is functioning properly, power to the gas valve will be shut off within 4 seconds of the pilot gas being shut off. If shut down takes longer, ignition control or gas valve may be defective.

14. LOW WATER TEMPERATURE SYSTEMS

In applications where the heating system requires supply water temperatures below 110 °F, a bypass line must be installed upstream of the boiler pump so that outlet water can be re-circulated to raise the inlet temp to a minimum of 110 °F. Balancing valves, preferably globe valves are used to adjust flow. (See figure 5)

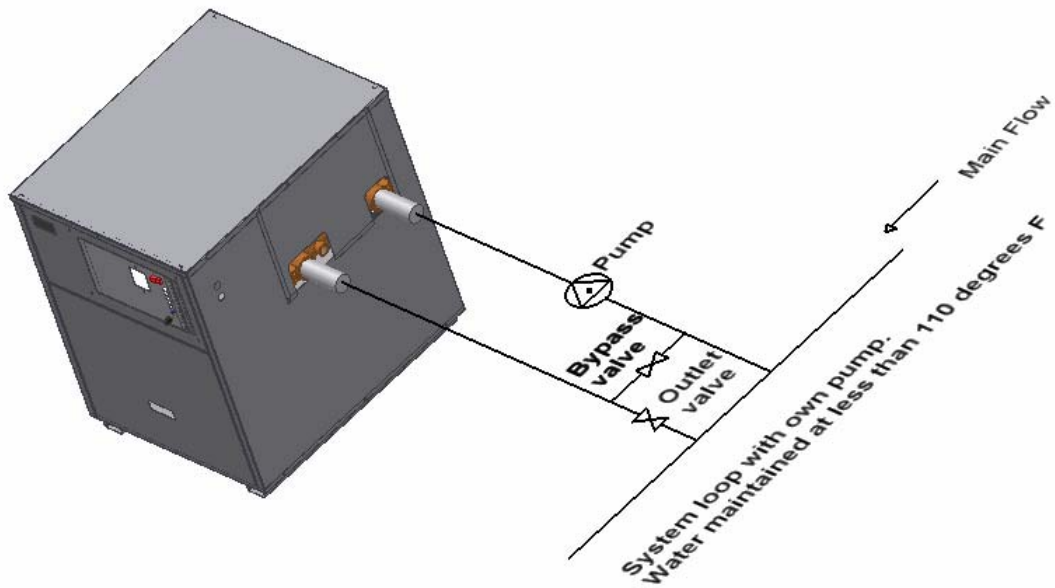

Figure 5

- Adjustment procedure.
 - a. Fully open bypass and outlet valves.
 - b. With boiler running, read inlet temperature after 15 minutes.
 - c. If the inlet temperature is less than 110 °F slowly close outlet valve until the inlet temperature climbs to 110 °F
 - d. If the inlet temperature is greater than 110 °F but not greater than 140 °F no further adjustment is required.
 - e. Check the inlet temperature after 5 minutes and make final adjustments.

15. INSTANTANEOUS WATER HEATER

An instantaneous water heater is designed to deliver hot water without the use of a storage tank. It is suitable for applications with variable load such as restaurants, condominiums, apartments and motels. (See figure 6) Call factory for recommendations.

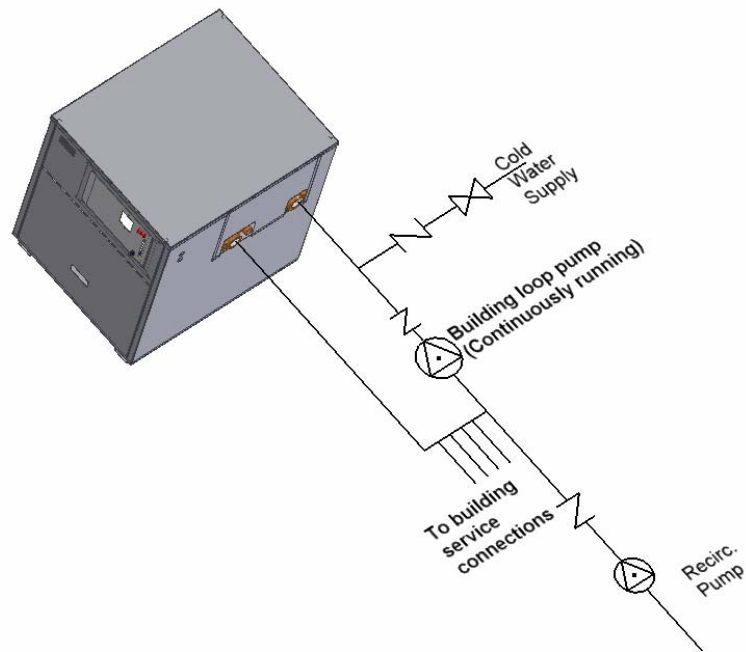

Figure 6

16. PILOT AND MAIN BURNER FLAMES

To maintain safe operation and the greatest efficiency of the boiler, check the main burner and pilot burner every six months for proper flame characteristics.

16.1. MAIN BURNER

The main burner, figure 7 should display the following characteristics;

- Acceptable CO and CO₂ levels for complete combustion.
- Light off smoothly.
- Reasonably quiet while running.
- Stable flame with minimum of lifting.
- Blue flame with natural gas, yellow tips with propane gas

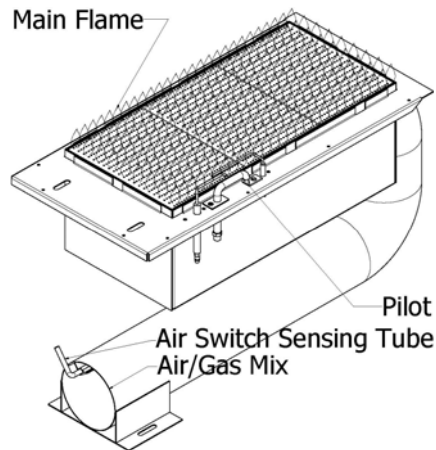

Figure 7

If burner characteristics do not match the above, check for proper air box pressure. Also look for accumulation of lint and other foreign material at fan air inlets. Typical air box settings are as follows (settings in brackets denotes condensing application):

MODEL	AIR BOX " W.C. (with burner firing)		FLUE SWITCH RECYCLE POINT " W.C	
	Left Burner	Right Burner	Left Burner	Right Burner
800	-	1.4 (1.7)	-	1.0 (1.4)
1000	-	1.9 (2.2)	-	1.5 (1.9)
1200	0.9 (1.1)	0.9 (1.1)	0.8 (0.9)	0.7 (0.9)
1400	0.9 (1.1)	1.4 (1.7)	0.7 (0.9)	1.1 (1.3)
1600	0.9 (1.1)	1.9 (2.2)	0.7 (0.9)	1.5 (1.8)
1800	1.6 (1.9)	1.6 (1.9)	1.2 (1.6)	1.2 (1.6)
2000	1.9 (2.2)	1.9 (2.2)	1.5 (1.9)	1.5 (1.9)

Depending on field conditions air box pressures will have to be adjusted accordingly. Always set the appliance for a CO₂ level in the range of 7.5% to 8.5 %.

A qualified service technician should follow this procedure when burner needs cleaning.

1. Shut off power and close main manual gas valve.
 - Allow burner to cool before removal.
2. Remove access cover screws.
 - Disconnect pilot gas at bulkhead fitting.
 - Disconnect ground wire and ignition wire.
 - Remove two wing nuts holding down burner.
 - Gently pull down and forward to disengage burner.
 - Remove burner being careful to not damage the igniter or ground electrodes.
3. Thoroughly clean burner. Check all ports and air channels for blockage.

4. Reinstall the burner being careful to fully engage the back of the burner box into the retaining slot in the combustion chamber base. Failure to properly locate the burner will result in erratic flame operation with the possibility of delayed ignition on light off.
5. Restore electrical power and gas supply to the boiler.
 - Following the lighting instructions put the boiler back into operation
 - Check for gas leaks and proper boiler and vent operation.

16.2. PILOT BURNER

Turn the pilot firing valve to off position and allow the boiler to try for ignition. Observe the spark making sure that it is strong and continuous.

If the spark is not acceptable the igniter will have to be adjusted. This can be readily accomplished after removing the main burner.

The spark gap should be $1/8''$ to $3/16''$. Make sure that the electrode does not appear overheated or fouled with carbon. It may be necessary to clean the ignition electrode using steel wool. Once the pilot appears to be properly set, reinstall it into the appliance making sure to properly tighten the pilot line connection.

If the pilot is removed from the main burner in the course of servicing the boiler, it is important to replace all gaskets and seals. These seals are intended to prevent the bypass of air around the pilot.

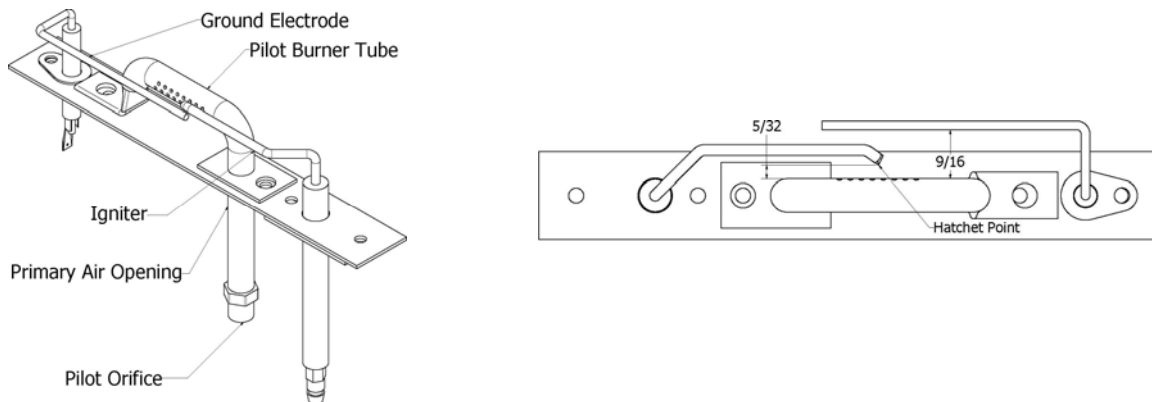

Figure 8

Once the spark is satisfactory, open the pilot gas and allow the pilot burner to light. Once air has been purged from the pilot line, the pilot flame should appear almost instantly at the initiation of spark. Cycle the pilot several times to confirm reliability. A properly set pilot will appear blue and will engulf the igniter and ground electrode. (See figure 8)

Open the firing valve and allow the main burner to light. The pilot must not extinguish. After running for 15 minutes, cycle the boiler to ensure that the pilot remains stable.

17. OPERATION AND SERVICE

OPERATION:

Before operating the boiler, the entire system must be filled with water, purged of air and checked for leaks. Do not use Stop leak or other boiler compounds. The gas piping must also be leak tested.

Any safety devices including low water cutoff, flow switch and high limit used in with this boiler must receive periodic inspection (every six months) to assure proper operation. A low water cutoff of the float type should be flushed every six months. All relief valves should be inspected and manually operated every six months.

For your safety follow the lighting and operating instructions below and on the boiler.

To turn on main burner, slowly open firing valve after pilot is established.

Set primary system controller to desired temperature.

To turn off boiler close main manual gas valve, close pilot manual valve and turn off electric power to system.

SERVICE:

Disconnect main power and turn off gas supply before servicing unit.

To remove and clean the burner, follow the detailed procedure in section 15 of this manual

After the first season of operation inspect the heat exchanger and venting . Follow the detailed instructions in section 6 of this manual.

CAUTION: Label all wires prior to disconnection when servicing controls. Wiring errors can cause improper and dangerous operation. Verify proper operation after servicing.

Any audible sounds in the equipment, like pinging, crackling or hissing are indications of scaling or lack of sufficient water flow. Under these conditions the boiler must be shut down immediately and the heat exchanger checked for damage. If the exchanger is damaged from scaling, it is not covered by warranty.

Should your equipment be subjected to fire, flood or some other unusual condition, turn off all gas and electrical supply. if you are unable to turn off the gas , call your gas company or gas supplier at once. Do not put the unit back in operation until it has been checked by a qualified agency to ensure that all controls are functioning properly.

Units that are not operated for a period of 60 days or more are considered seasonal operations. It is recommended that before returning one of these units to service, the proper operation of all controls be checked by a qualified service technician.

18. LIGHTING INSTRUCTIONS

1. Turn off electric power to boiler.
2. Close main manual valve and main firing valve and wait 5 minutes.
3. Set primary system controller to desired temperature.
4. Open pilot valve.
5. Turn on electric power to boiler. The electrode at the pilot should begin to spark after pre-purge is complete. The pilot valve will open to permit gas flow to the pilot.
6. There is a 15 second trial for ignition, which is enough time to light the pilot if air is not present in the pilot line. If pilot fails to light and you suspect air in the line, close the main manual valve and repeat lighting steps 1 thru 5.
7. Once the pilot lights, it should envelope the ignition rod and ground electrode. The pilot can be adjusted by removing the pilot regulator cover and turning the adjustment screw counter clockwise to increase it or clockwise to decrease it.
8. Open the main manual and main firing valves to allow gas to reach the main burner. If the main burner fails to ignite, turn the firing valve off and check to see that the pilot is burning. If not, repeat lighting procedure steps 1 thru 7.

TO TURN OFF BOILER: Close main manual valve and main firing valve and turn off electric power to system.

19. TROUBLE SHOOTING GUIDE

SYMPTOM	SOLUTION
1. Power light is not lit when switch is flipped to "ON"	<ul style="list-style-type: none"> • Check wiring to switch. • Check circuit breaker. • Check fuse.
2. Water flow light remains off.	<ul style="list-style-type: none"> • Verify that pump is running. • Check wiring to flow switch.
3. Pilot sparks but does not light	<ul style="list-style-type: none"> • Verify that main manual valve is open. • Follow lighting instructions to bleed air out of pilot line. • Remove main burner and inspect for moisture or dirt in pilot or in pilot line. • Verify that pilot is sealed to main burner base. • Verify that gas connections are tight.
4. Pilot lights momentarily, goes out and then sparks again repeatedly	<ul style="list-style-type: none"> • Observe pilot for proper flame. Adjust if necessary. • Check pilot flame signal. Properly set pilot to generate 1.5 μA. D.C. on average. • Remove main burner and ensure that igniter and ground electrodes are positioned properly. Clean with steel wool if necessary. • Verify that back of burner box is fully engaged into the retaining slot in the combustion chamber base.
5. Pilot lights but main burner does not fire.	<ul style="list-style-type: none"> • Verify that high limit is set high enough to prevent short cycling. • Check pilot flame signal (μA). • Adjust pilot pressure for steady flame • Remove main burner. Check position of igniter and ground electrode. Clean with steel wool if necessary.
6. Main burner lights but cycles off after a few minutes	<ul style="list-style-type: none"> • Verify that high limit is set high enough to prevent short cycling. • Adjust pilot pressure for steady flame • Remove main burner. Adjust pilot shield and clean ignition sensor.
7. Boiler starts to whine as the temperature rise increases.	<ul style="list-style-type: none"> • Verify that all air is bled from system. • Verify that the static pressure in cold system is at least 15 psig. • Check temperature rise across boiler to ensure adequate water flow. • If necessary, increase static water pressure and decrease gas pressure.

20. TYPICAL GAS TRAIN

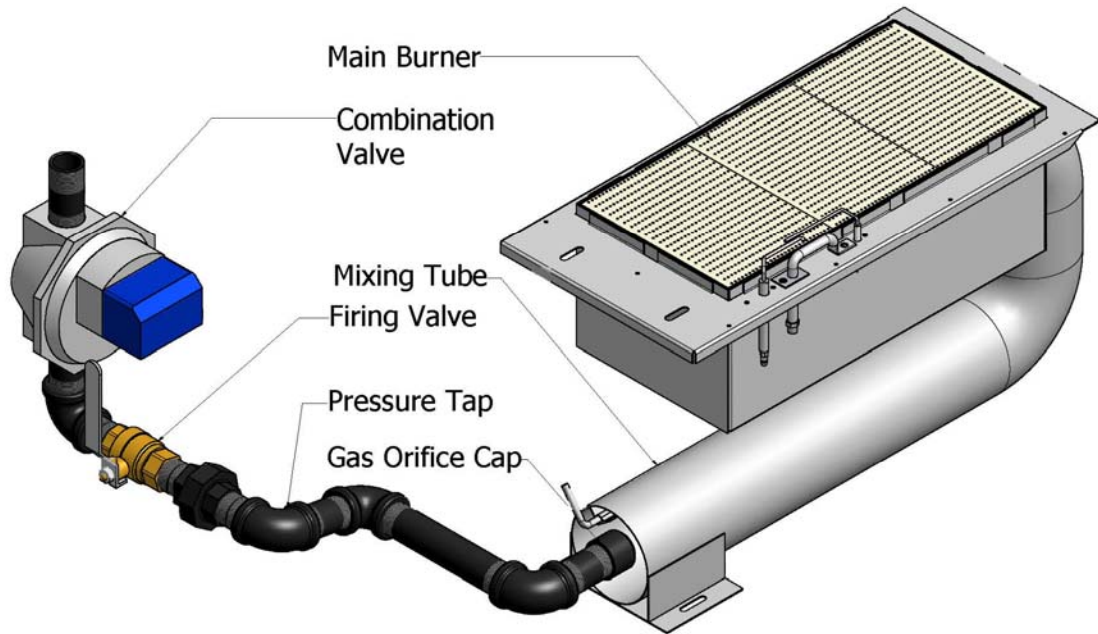
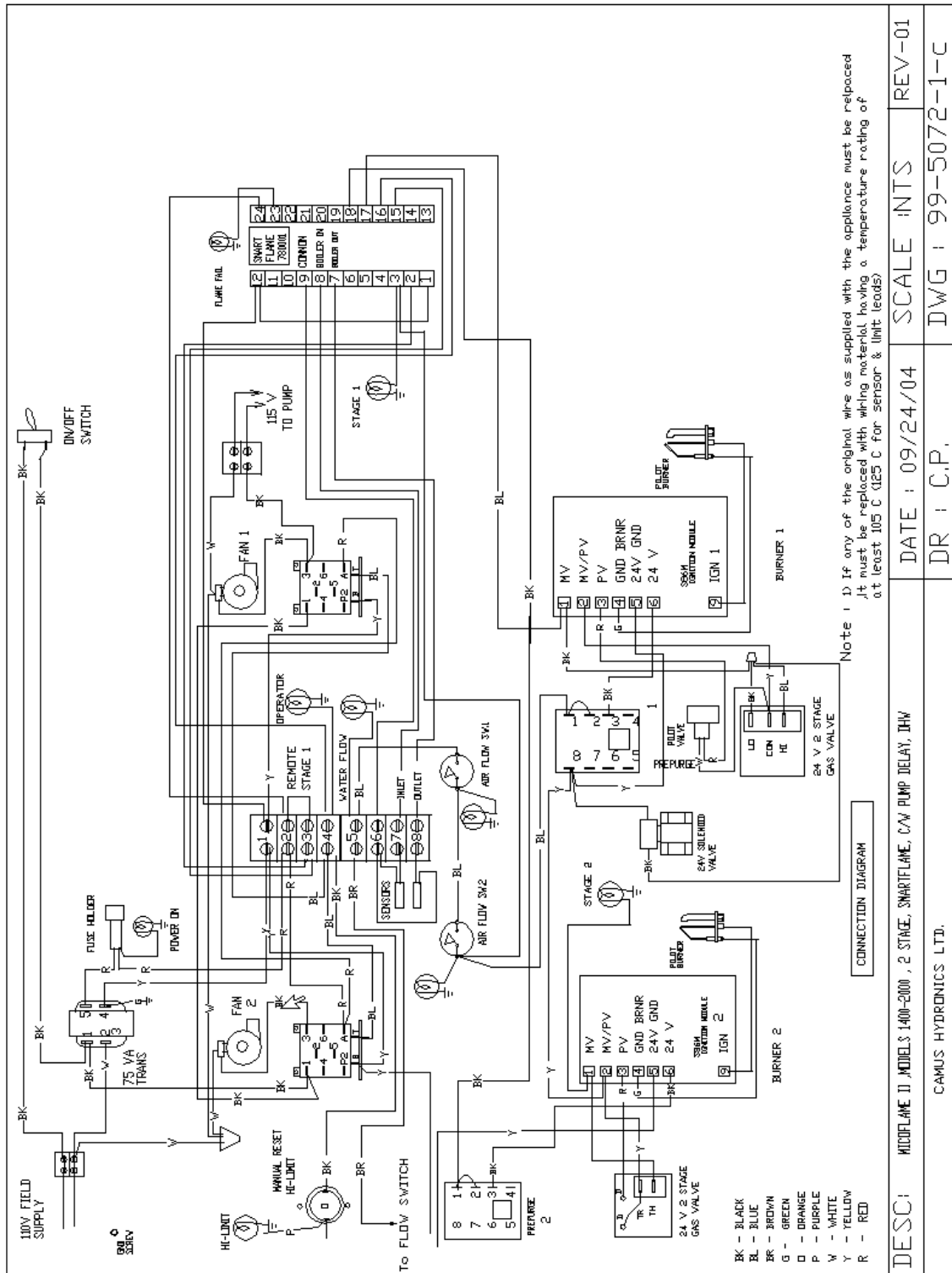

Figure 9

21. ELECTRICAL DIAGRAMS

Each MicoFlame series 2 boiler will be provided with its own wiring diagram to guarantee that any options ordered with the unit are properly detailed.

The following diagram 99-5072 and 99-5073 are provided as typical samples only.



DESC: MICROFLAME D, MODEL 3 1400-2000, 2 STAGE, SMARTFLAME, CW PUMP DELAY, DHW	DATE: 09/24/04	SCALE: NTS	REV: 01
CAMUS HYDRONICS LTD.	DR: C.P.	DWG: 99-5072-1-C	

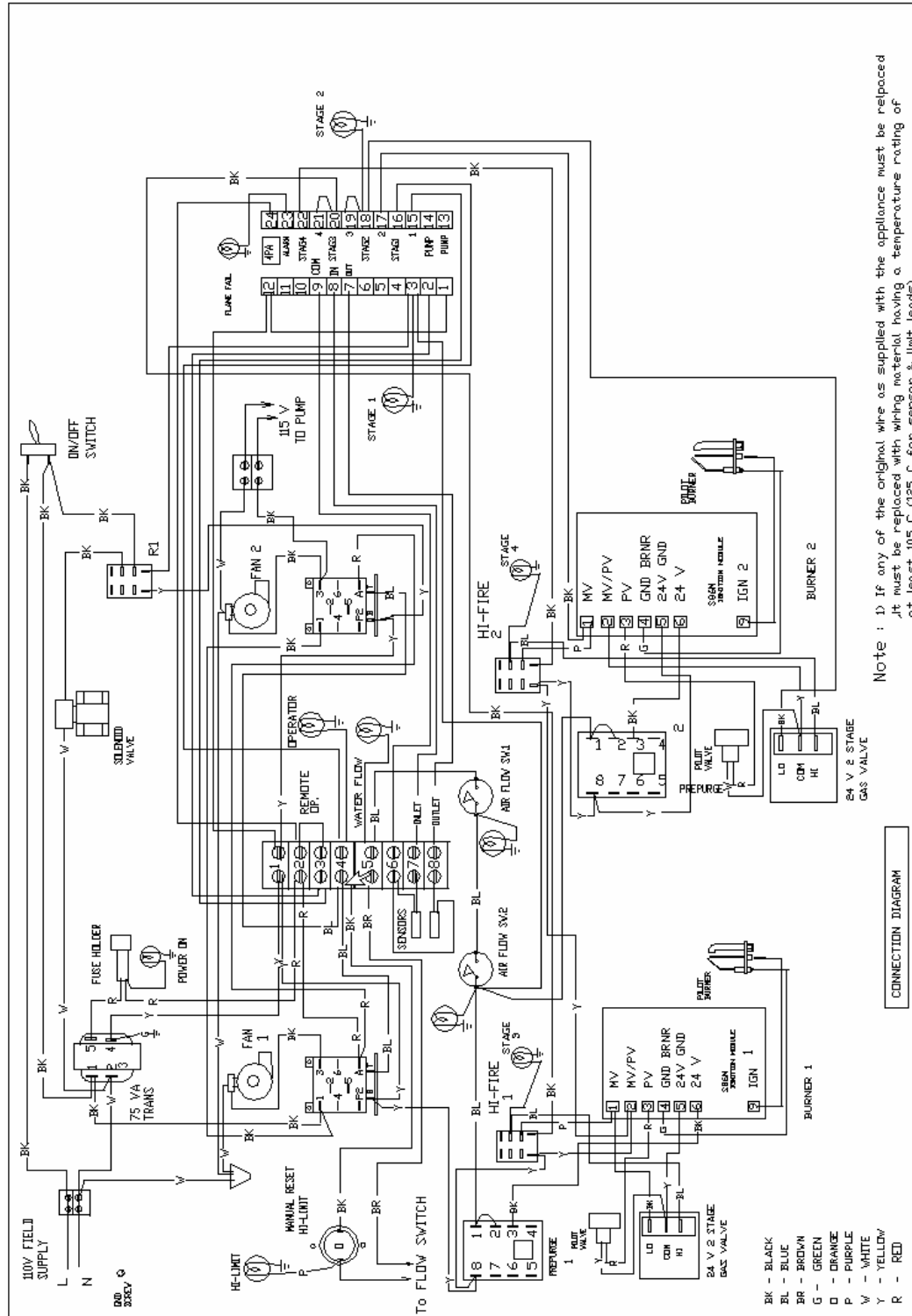

Note : 1) If any of the original wire as supplied with the appliance must be replaced
 it must be replaced with wiring material having a temperature rating of
 at least 105 C (225 F for sensor & limit leads)

CONNECTION DIAGRAM

DESC: MICROFLAME II, MODELS 1200-2000, 4 STAGE, SMARTFLAME 4PA, CW PUMP DELAY	DATE : 08/05/04	SCALE : NTS	REV: 01
CAMUS HYDRONICS LTD.	DR : C.P.	DWG : 99-5073-1-C	

22. EXPLODED VIEW

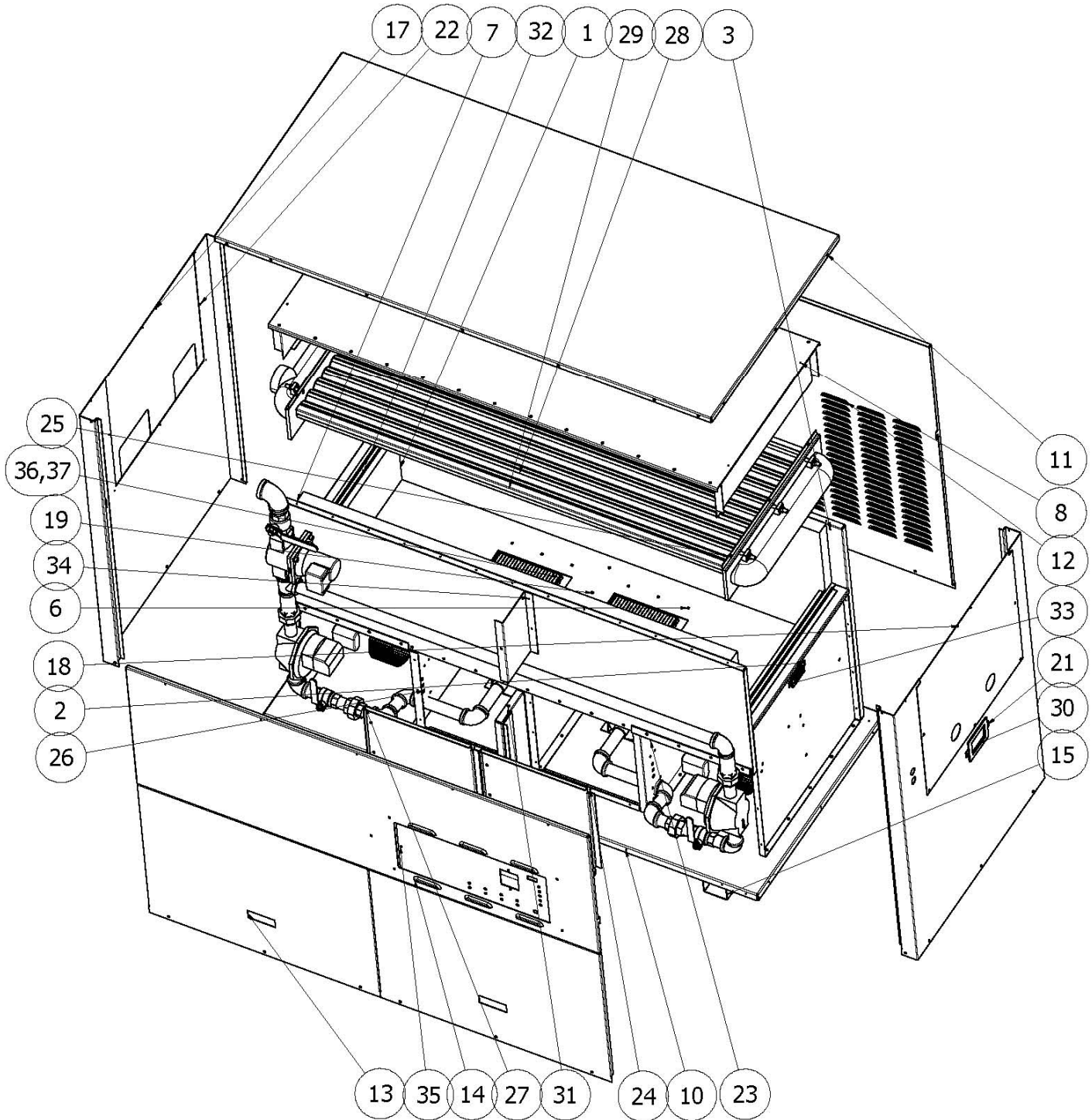

23. MICO FLAME REPLACEMENT PARTS LIST

Part Number	Part Name	Model Number							
		800	1000	1200	1400	1600	1800	2000	
1	Combustion Chamber End Panel - Left	14-4100	14-4100	14-4100	14-4100	14-4100	14-4100	14-4100	
2	Combustion Chamber End Panel - Right	14-4101	14-4101	14-4101	14-4101	14-4101	14-4101	14-4101	
3	Combustion Chamber Rear Panel	14-4102	14-4102	14-4102	14-4102	14-4102	14-4102	14-4102	
4	Combustion Chamber Support - Left	14-4103	14-4103	14-4103	14-4103	14-4103	14-4103	14-4103	
5	Combustion Chamber Support - Right	14-4104	14-4104	14-4104	14-4104	14-4104	14-4104	14-4104	
6	Combustion Chamber Base	14-4105	14-4105	14-4105	14-4105	14-4105	14-4105	14-4105	
7	Combustion Chamber Upper Front	14-4106	14-4106	14-4106	14-4106	14-4106	14-4106	14-4106	
8	Flue Collector Top	14-4107	14-4107	14-4107	14-4107	14-4107	14-4107	14-4107	
9	Flue Collector End Bracket	14-4108	14-4108	14-4108	14-4108	14-4108	14-4108	14-4108	
10	Base Panel	14-4109	14-4109	14-4109	14-4109	14-4109	14-4109	14-4109	
11	Outer Jacket Top Cover	14-4110	14-4110	14-4110	14-4110	14-4110	14-4110	14-4110	
12	Outer Jacket Back Panel	14-4111	14-4111	14-4111	14-4111	14-4111	14-4111	14-4111	
13	Outer Jacket Front Lower Panel	14-4112	14-4112	14-4112	14-4112	14-4112	14-4112	14-4112	
14	Outer Jacket Front Upper Panel	14-4113	14-4113	14-4113	14-4113	14-4113	14-4113	14-4113	
15	Leg	14-4114	14-4114	14-4114	14-4114	14-4114	14-4114	14-4114	
16	Stiffener	14-4115	14-4115	14-4115	14-4115	14-4115	14-4115	14-4115	
17	Inlet Outlet Side Access Panel	14-4116	14-4116	14-4116	14-4116	14-4116	14-4116	14-4116	
18	Return Side Access Panel	14-4117	14-4117	14-4117	14-4117	14-4117	14-4117	14-4117	
19	Combustion Chamber Support - Centre	N/A	N/A	14-4118	14-4118	14-4118	14-4118	14-4118	
20	Flue Collector Outlet	14-4119	14-4119	14-4119	14-4119	14-4119	14-4119	14-4119	
21	Outer Jacket Side Panel - Right	14-4131	14-4131	14-4131	14-4131	14-4131	14-4131	14-4131	
22	Outer Jacket Side Panel - Left	14-4132	14-4132	14-4132	14-4132	14-4132	14-4132	14-4132	
23	Fan Mounting Support - Right	N/A	N/A	14-4133	14-4133	14-4133	14-4133	14-4133	
24	Burner Door Stop	14-4134	14-4134	14-4134	14-4134	14-4134	14-4134	14-4134	
25	Heat Exchanger Header Stop Bar	14-4138	14-4138	14-4138	14-4138	14-4138	14-4138	14-4138	
26	Fan Mounting Support - Left	14-4139	14-4139	14-4139	14-4139	14-4139	14-4139	14-4139	
27	Burner Door	14-4140	14-4140	14-4140	14-4140	14-4140	14-4140	14-4140	
28	V Baffles	14-4141	14-4141	14-4141	14-4141	14-4141	14-4141	14-4141	
29	HX Front and Back Baffles	14-4142	14-4142	14-4142	14-4142	14-4142	14-4142	14-4142	
30	Outer Jacket Sight Glass Frame	14-4151	14-4151	14-4151	14-4151	14-4151	14-4151	14-4151	
31	Outer Jacket Door Jam	14-4152	14-4152	14-4152	14-4152	14-4152	14-4152	14-4152	
32	Heat Exchanger Support Weldment	14-4153	14-4153	14-4153	14-4153	14-4153	14-4153	14-4153	
33	Inner Jacket Sight Glass Frame	14-4154	14-4154	14-4154	14-4154	14-4154	14-4154	14-4154	
34	Outer Jacket Top Panel Support	14-4155	14-4155	14-4155	14-4155	14-4155	14-4155	14-4155	
35	Control Panel Assembly	14-4160	14-4160	14-4160	14-4160	14-4160	14-4160	14-4160	
36	Two Tiles Burner Box Assembly	N/A	N/A	14-4162	14-4162	14-4162	N/A	N/A	
37	Three Tiles Burner Box Assembly	14-4163	14-4163	N/A	14-4163	14-4163	14-4163	14-4163	
38	Economizer Cover	14-4146	14-4146	14-4146	14-4146	14-4146	14-4146	14-4146	
39	Economizer Assembly	14-4148	14-4148	14-4148	14-4148	14-4148	14-4148	14-4148	

WARRANTY

GENERAL

Camus Hydronics Limited ("Camus"), extends the following LIMITED WARRANTY to the owner of this appliance, provided that the product has been installed and operated in accordance with the Installation Manual provided with the equipment. Camus will furnish a replacement for, or at Camus option repair, any part that within the period specified below, shall fail in normal use and service at its original installation location due to any defect in workmanship, material or design. The repaired or replacement part will be warranted for only the unexpired portion of the original warranty. This warranty does not cover failures or malfunctions resulting from: (1) Failure to properly install, operate or maintain the equipment in accordance with Camus' manual; (2) Abuse, alteration, accident, fire, flood, foundation problems and the like; (3) Sediment or lime buildup, freezing, or other conditions causing inadequate water circulation; (4) Pitting and erosion caused by high water velocity; (5) Failure of connected systems devices, such as pump or controller; (6) Use of non-factory authorized accessories or other components in conjunction with the system; (7) failing to eliminate air from, or replenish water in, the connected water system; (8) Chemical contamination of combustion air or use of chemical additives to water.

HEAT EXCHANGER

If within TEN years after initial installation of the appliance, a heat exchanger, shall prove upon examination by Camus to be defective in material or workmanship, Camus will exchange or repair such part or portion on the following pro rated limited warranty. (1) Years one through five - standard warranty (2) Years six through ten - replacement purchase price pro rated at the following schedule: Year six - 60%, Year seven - 65%, Year eight -70%, Year nine -75% Year ten -80% of the current list price of the current list price This term is reduced to FIVE years if the appliance is used for other than hydronic space heating.

Heat Exchanger shall be warranted for (20) years from date of installation against "Thermal Shock" (excluded, however, if caused by appliance operation at large changes exceeding 150 °F between the water temperature at intake and appliance temperature, or operating at appliance temperatures exceeding 230 °F).

BURNER

If within FIVE years after initial installation of the appliance a burner shall prove upon examination by Camus to be defective in material or workmanship, Camus will exchange or repair such part or portion.

ANY OTHER PART

If any other part fails within one (1) year after installation, or eighteen (18) months from date of factory shipment based on Camus' records, whichever comes first. Camus will furnish a replacement or repair that part. Replacement parts will be shipped f.o.b. our factory.

HOW TO MAKE A CLAIM

Any claim under this warranty shall be made directly to Camus Hydronics Limited Canadian Head Office

SERVICE LABOR RESPONSIBILITY

Camus shall not be responsible for any labour expenses to service, repair or replace the components supplied. Such costs are the responsibility of the owner.

DISCLAIMERS

Camus shall not be responsible for any water damage. Provisions should be made that in the event of a water/appliance or fitting leak, the resulting flow of water will not cause damage to its surroundings.

Name of Owner	_____	Name of Dealer	_____
Address	_____	Address	_____
	_____		_____
Model No.	_____	Serial No.	_____
Date of Installation:	_____	Date of Initial Operation:	_____

6226 Netherhart Road, Mississauga, Ontario, L5T 1B7, CANADA

CAMUS Hydronics is a manufacturer of replacement parts for most copper finned water heaters and heating boilers as well as a



The CAMUS CERTIFIED! Seal assures you that Reliability, Efficiency & serviceability are built into every single unit! For more information

supplier of specialty HVAC products. Our service line is open 24 hours, 7 days a week!

on our innovative products from CAMUS Hydronics Limited, call 905-696-7800 today.



CAMUS HYDRONICS LTD.

6226 Netherhart Road Drive, Mississauga, Ontario L5T 1B7

TEL: 905-696 7800 FAX: 905-696 8801